

RIDE SHOCKS™

INST-1000-031

U-Bolt Flip Kit with Bump Stops 2005-2023 Toyota Tacoma Installation Guide | SKU: 314001401



www.RideShocks.com

A FEW WORDS ON PRODUCT SAFETY AND MESSAGING:

Motor vehicles and off road motor sports/use involve high levels of risks and variables including speed, terrain, overall suspension component choice, driver behavior and other variables outside Ride Shocks knowledge or influence. It follows that we are unable to foresee every combination of variables and these installation instructions do not reflect all product safety information which may be required to reduce risk of accident or injury related to your vehicle and selected modifications.

Before installation, please review the following safety information and installation instructions. Within these Instructions important safety information is generally preceded by one of three signal words indicating the relative risk of injury.

The signal words mean:

⚠️ WARNING A hazardous situation which, if not avoided, could result in death or serious injury. You CAN be Killed or Seriously Hurt if you don't follow instructions.

⚠️ CAUTION A hazardous situation which, if not avoided, could result in minor or moderate injury. You CAN be moderately HURT and also may suffer property damage if you don't follow instructions.

NOTICE Careful attention is required to this instruction or operation but does generally not relate to personal injury. Damage to your Ride Shocks product or other property may result if you don't follow instructions.

⚠️ WARNING Suspension Modified with Tuned Shock Components/Higher Risk of Roll-over or Other Accident

⚠️ WARNING: HIGHER ROLLOVER RISK		
	Avoid Excessive Speeds, Abrupt Maneuvers, Surfaces/Obstacles Which May Induce a Tripping Moment. All Occupants Buckle UP & USE Supplemental Restraints.	

The suspension of this vehicle has been optimized for off-road utility through installation of Ride Shocks products, which may increase ride height, modify damping/rebound and other suspension parameters. The suspension feel and handling may be different than an unmodified vehicle.

To reduce risk of roll-over or other accident always:

- Routinely inspect suspension components. **IF DAMAGED, DO NOT USE UNTIL REPAIRED OR REPLACED.**
- Do Not modify or substitute components of the Ride Shocks suspension products.
- Use of oversize tire/wheel combinations may increase stopping distances, ride height and/or compromise performance of vehicle stability control and other systems.
- Many states have restrictions on height and suspension modifications for highway use vehicles. Owners & drivers are exclusively responsible for construction and compliance of their vehicles.
- For additional safety messaging consult your OEM owners manual and off road supplements.

⚠️ WARNING (CA residents) Cancer and Reproductive Harm - www.P65Warnings.ca.gov. Handling passenger or off-highway motor vehicle parts can expose you to chemicals such as phthalates and lead, which can cause cancer and reproductive harm. To minimize exposure, service the vehicle in a well-ventilated area, wear gloves, and wash your hands. For more information see: <https://www.p65warnings.ca.gov/fact-sheets/motor-vehicle-parts>.

Read and follow all instructions and understand all safety messaging before beginning Installation. This installation requires intermediate mechanical skills and should be performed by a professional mechanic with access to a lift and means of securing the vehicle.

WARRANTY:

No Warranty. There is no warranty, express or implied, other than as expressly set forth or referred to herein and, in particular, neither Party makes any warranties to each other or any other person or entity, whether express, implied or statutory, as to the description, quality, merchantability, completeness or fitness for any purpose of any services, products or information provided hereunder or described herein, or as to any other matter all of which warranties are hereby excluded and specifically disclaimed.. **THE SAFETY, EFFECTIVENESS, AND PERFORMANCE OF THIS PRODUCT IS DIRECTLY RELATED TO THE MANNER IN WHICH IT IS INSTALLED, USED, AND/OR MAINTAINED. THE USER ASSUMES ALL RISK.**

314001401 - PARTS LIST

ITEM #	DESCRIPTION	PART #	QTY
1	U-Bolt Plates, 2005-2023 Tacoma	3002-003-21	2
2	U-Bolt Kit includes: (4) 8.5" U-Bolts, (8) washers (8) nuts	3003-028	1
3	Flat Head Screws, Fine Thread 8x (10-32 X 1.00", 2.50", 1.75")	3003-014	1
4	Ride Shocks Foam Bump Stops	3004-000-45	8
5	Ride Shocks Bump Stop Holder (1.05" Tall)	2000-083-1	8
6	Ride Shocks Bump Stop Riser (1.00" Tall)	3002-004-100-1	2
7	Ride Shocks Bump Stop Riser (0.50" Tall)	3002-004-050-1	2
8	Ride Shocks Bump Stop Riser (0.25" Tall)	3002-004-025-1	2

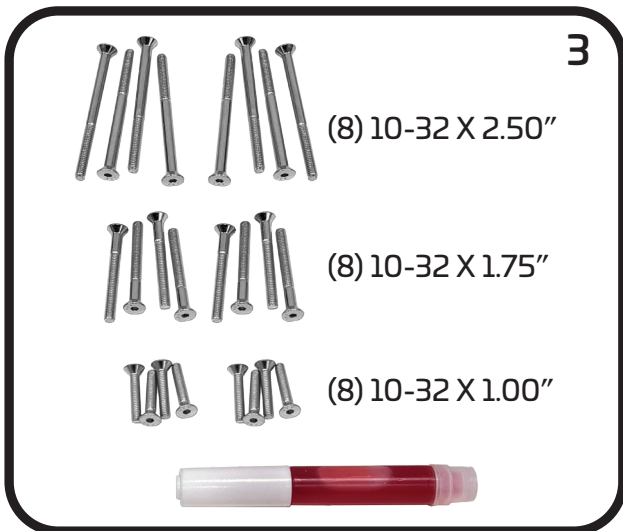
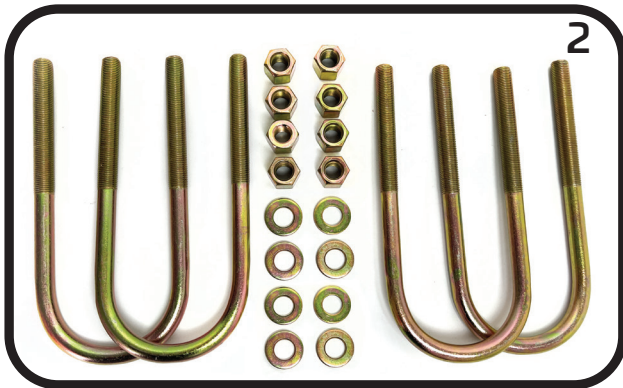













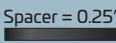
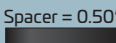
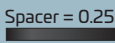
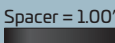
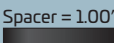

BUMP STOP MEASUREMENT CHART

- Use the chart below to find the correct spacer length to suit your specific vehicle.
- Using the incorrect bump stop spacer length can damage your vehicle. If you are unsure about which spacer to use, please contact our support team.
- If the recommended spacer length is not available, round up to the next spacer height.
- If you have a lift block, you will need to subtract it's height from the total spacer height.
- Be sure to choose the correct screw length to go along with your specific spacer height. This will ensure you can properly tighten everything down without damaging components.
- Use thread locker on the screws that attach the spacer stack, to ensure that they remain in place.

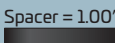
BUMP STOP SPACER COMBINATIONS | CORRESPONDING SCREWS

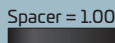
* Using the correct screw length is crucial to avoid damaging these components.

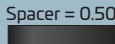
HEIGHT = 1.00"	HEIGHT = 1.25"	HEIGHT = 1.50"	HEIGHT = 1.75"	HEIGHT = 2.00"	HEIGHT = 2.25"	HEIGHT = 2.50"	HEIGHT = 2.75"
Holder = 1.00" 	Holder = 1.00" 	Holder = 1.00" 	Holder = 1.00" 	Holder = 1.00" 	Holder = 1.00" 	Holder = 1.00" 	Holder = 1.00" 
Spacer = 0.25" 	Spacer = 0.25" 	Spacer = 0.50" 	Spacer = 0.25"  Spacer = 0.50" 	Spacer = 1.00" 	Spacer = 1.00"  Spacer = 0.25" 	Spacer = 1.00"  Spacer = 0.50" 	Spacer = 1.00"  Spacer = 0.50"  Spacer = 0.25" 
Screw Length = 1.00" Use for spacers stacks 1.00"-1.50"	Screw Length = 1.00" Use for spacers stacks 1.00"-1.50"	Screw Length = 1.00" Use for spacers stacks 1.00"-1.50"	Screw Length = 1.75" Use for spacers stacks 1.75"-2.25"	Screw Length = 1.75" Use for spacers stacks 1.75"-2.25"	Screw Length = 1.75" Use for spacers stacks 1.75"-2.25"	Screw Length = 2.50" Use for spacers stacks 2.50" & over	Screw Length = 2.50" Use for spacers stacks 2.50" & over

* If the recommended spacer length is not available, round up to the next spacer height.

LEAF PACK	LEAF PACK THICKNESS	KRS-AT52121-01 KRS-AT52121-01A	KRS-25001-121 KRS-25001-121A	FOX-883-24-007 FOX-883-26-007	FOX-883-24-006-TACO FOX-883-26-006-TACO	FOX-985-24-116 FOX-985-26-116	FOX-985-24-117 FOX-985-26-117	FOX-985-24-118 FOX-985-26-118	FOX-883-26-112	FOX-883-26-113	RIDE SHOCKS 52541**** (ALL)
STOCK	1.68"	2.00"	1.75"	2.25"	3.25"	1.25"	2.25"	2.75"	2.00"	3.00"	2.00"
ICON RXT-1	2.00"	1.75"	1.50"	2.00"	3.00"	1.00"	2.00"	2.50"	1.75"	2.75"	1.50"
ICON RXT-2	2.05"	1.50"	1.25"	2.00"	3.00"	0.75"	1.75"	2.25"	1.75"	2.75"	1.50"
ICON RXT-3	2.25"	1.50"	1.25"	1.75"	2.75"	0.75"	1.75"	2.25"	1.50"	2.50"	1.25"
DEV J66/N98	2.63"	1.00"	0.75"	1.50"	2.50"	0.25"	1.25"	1.75"	1.00"	2.00"	1.00"
DEV U402-1	2.50"	1.25"	1.00"	1.50"	2.50"	0.50"	1.50"	2.00"	1.25"	2.25"	1.00"
DEV U402-2	2.75"	1.00"	0.75"	1.25"	2.25"	0.25"	1.25"	1.75"	1.00"	2.00"	0.75"
DEV U402-3	3.00"	0.75"	0.50"	1.00"	2.00"	0.00"	1.00"	1.50"	0.75"	1.75"	0.50"
AAL Without Overload	1.87"	1.75"	1.50"	2.25"	3.25"	1.00"	2.00"	2.50"	1.75"	2.75"	1.75"
AAL With Overload	2.45"	1.25"	1.00"	1.50"	2.50"	0.50"	1.50"	2.00"	1.25"	2.25"	1.25"
OME Medium Duty	2.60"	1.00"	0.75"	1.50"	2.50"	0.25"	1.25"	1.75"	1.00"	2.00"	1.00"
OME Heavy Duty	2.99"	0.75"	0.50"	1.00"	2.00"	0.00"	1.00"	1.50"	0.75"	1.75"	0.50"

INSTALLATION INSTRUCTIONS



TOOLS NEEDED

Sockets / Wrenches: 22mm, 1/8" Hex Wrench

Equipment: Floor Jack & Jack Stands, Angle Grinder w/Cut-Off Wheels.

Estimated Install Time: 1 Hour

1. Attach the spacer combination appropriate to your vehicle onto the u-bolt flip plates following the bump stop measurement chart. Be sure you use the correct spacer/screws combination. *Use a few drops of the supplied red thread locker and torque to 18 in-lbs.

⚠ WARNING 2. Park truck on flat level surface. Jack up the rear of the truck, rest axle on jack stands, and remove wheels. To keep axle from shifting, complete one side at a time before moving on to the other side.

3. Remove factory u-bolts and bump stops.

4. Place u-bolt flip plate with bump stop holder/spacer(s) on top of leaf pack, align pin to center of plate. Orient with pointed end facing outwards, towards tire.

5. Install u-bolts and secure with washers and nuts. Tighten nuts evenly. Torque U-Bolt nuts to 80 ft-lbs.

6. It may be necessary to trim u-bolts. No part of the u-bolt threads should stick up past the top of the aluminum Bump Stop Holder. This is to prevent the frame of the truck coming in contact with the bolt threads when the suspension bottoms out completely.

*If you are only running the bump stop spacer holder only, with no other spacers, you will need to trim the bolt threads flush with the tops of the nuts.

7. Install foam bump stop by pushing it into the bump stop holder.

8. Re-install wheels and torque lug nuts to factory specs.

9. Repeat on the other side.

*Re-torque U-bolts after 500 miles.



BUMP STOP TRIMMING FOR VEHICLES WITH LESS UP TRAVEL

When a vehicle has less than 5" of up travel, it is advised to trim the top rung off of the bump stop. This allows the suspension to move freely without contacting the bump stop as often and improved ride quality.

*** DO NOT TRIM MORE THAN 0.75" OFF THE TOP!**

⚠ WARNING To trim, just use a box cutter and roll the bump stop as you cut into the top indent. After you cut fully around the bump stop, you should be able to twist off the top piece.



UNIQUE LEAF SPRING / SPACER HEIGHT CALCULATOR

Use this page to calculate the correct length bump stop spacer needed with a shock & leaf spring combination not listed in our Bump Stop Measuring Chart.

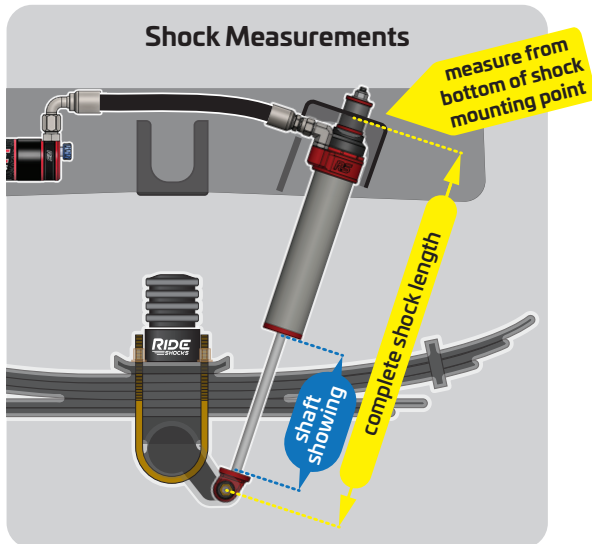

Method:

1. Measure the shock shaft showing from the bottom of the shock body to the top of the rod end. **DO NOT** account for any shaft bumpers on your shock *if present*.
2. Measure the complete shock length, from the inside of the mounting point of the frame down to the center of the mounting bolt at the bottom.
3. Subtract the "shaft showing" measurement from the "complete shock length" measurement. This number will represent **DIM A**.
4. Measure your vehicles leaf pack thickness. If you have a lift block, make sure to include this in your measurement. This number will represent **DIM B**.

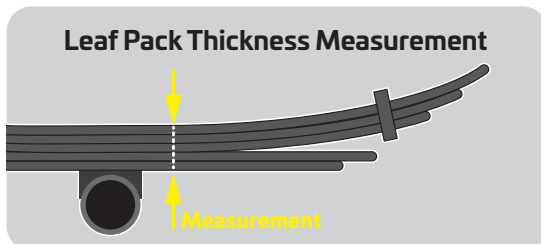

SPACER HEIGHT CALCULATION:

$$\mathbf{DIM\ A - DIM\ B - 12.20''}$$

EXAMPLE: (Tacoma Ride Shocks: **DIM A = 15.73"** - Deaver U402-1: **DIM B = 2.50"** - 12.20" = **1.03"**)

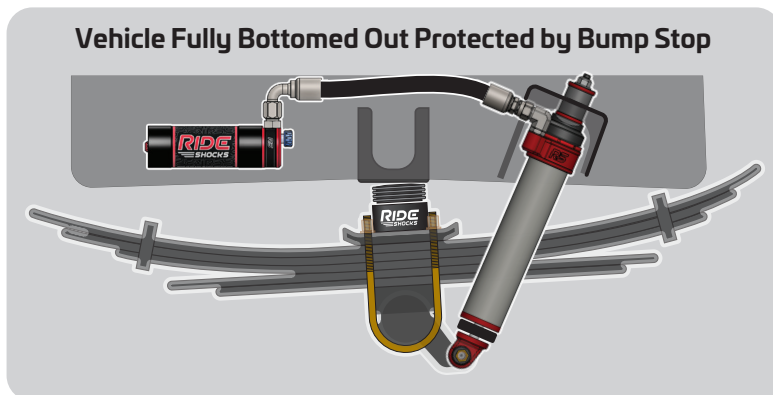

From this example, the correct spacer to use with this combination is the 1.00" spacer.
For whatever number you calculate, you will round to the nearest available bump height spacer.