



INSTALLATION INSTRUCTIONS



COMPONENT: UPPER CONTROL ARMS

PART #: 80502

FITS: 2021+ FORD F150

PART #	DESCRIPTION	QUANTITY
99855L	LEFT UPPER CONTROL ARM	1
99855R	RIGHT UPPER CONTROL ARM	1
*FK-WSSX16T-1	1" UNIBALL (STAINLESS) W/ PTFE LINER	2
*30604	SNAP RING / 1" UNIBALL	2
*100916	SPACER - 1" - 9/16" HI-MISALIGNMENT	2
*10034-TCF	SPACER - 3/4" HI-MISALIGNMENT	2
60684	BUSHING - URETHANE HALF	8
68051	INNER SLEEVE	4
10255	BOLT - 9/16" - 18 x 5.50" GRADE 8 (ZINC)	2
12203	WASHER - 9/16" AN (GOLD ZINC)	2
30006	TAPERED SPINDLE ADAPTER: 9/16" ID	2
12204	WASHER: 9/16" SAE (GOLD ZINC)	2
11202	NUT - 9/16" - 18 C-LOCK (ZINC)	2
10005	ZERK FITTING: 1/4"-28 90 DEGREE	5
*THESE PARTS ARE PRE-INSTALLED IN THE UCA		

REQUIRED TOOLS

- 15mm Wrench
- 18mm Wrench or Socket
- 21mm Wrench or Socket
- Dead Blow Hammer
- Hammer
- Drill w/ 9/16" Bit
- Pry Bar
- Grease Gun
- Anti-Sieze

IMPORTANT

- Before starting install, make sure the vehicle is supported securely on jack stands.
- Apply generous amounts of grease to the outside of sleeves, outer face of urethane bushings and I.D. of the urethane bushings prior to install.
- When installing the zerk fittings take care not to over tighten them as they are hollow and can snap off. When fully installed they will not sit all of the way flush with the pivot, just insert them two or three rotations until they are snug. Don't forget to have them pointing in the right direction so you can get a grease gun onto them once the arms are installed onto the vehicle.
- If excess powder coat is in the zerk holes, re-tap using a 1/4"-28 tap to clean up the threads.

STEP 1

Use an 18mm wrench to loosen the factory nylock nut that holds the ball joint to the steering knuckle. Do not remove the nut, as it will hold the suspension together for the next step.



STEP 2

With the upper ball joint nut loose, strike the steering knuckle near the top to shock the ball joint taper loose. When the taper breaks free you'll see the steering knuckle drop onto the ball joint nut.



STEP 3

Use an 18mm to loosen and remove the factory outer tie rod nut. Strike the steering knuckle where the tie rod attaches until the tie rod taper breaks free.



STEP 4

Use an 18mm to loosen and remove the factory lower shock nuts.

**STEP 5**

Use a 15mm to loosen all three upper shock nuts. Remove two of the upper nuts leaving one nut finger tight to keep the shock from falling out.



STEP 6

Now its time to remove the upper ball joint nut. Be careful, the vulcanized rubber bushings in the UCA are under a twisting force and when the nut is removed, the upper arm will want to spring up. To control this, push down on the upper arm just enough to take the load off the nut as you spin it off. Once the nut is off you can slowly release the pressure on the upper arm and it will relax upward to a neutral position.



STEP 7

While holding the shock body and pushing the shock upward, remove the one remaining top nut that is keeping the shock from falling out. With the nut removed you can now remove the factory shock. It may be necessary to use a pry bar to pry the lower control arm downward enough to get the studs out of the coil bucket and/or the lower shock mount from the lower control arm.



STEP 8

With the shock removed, you can now loosen and remove the two bolts that mount the upper control arm to the frame using an 18mm and 21mm wrench or socket. Once they're out, remove the factory UCA.

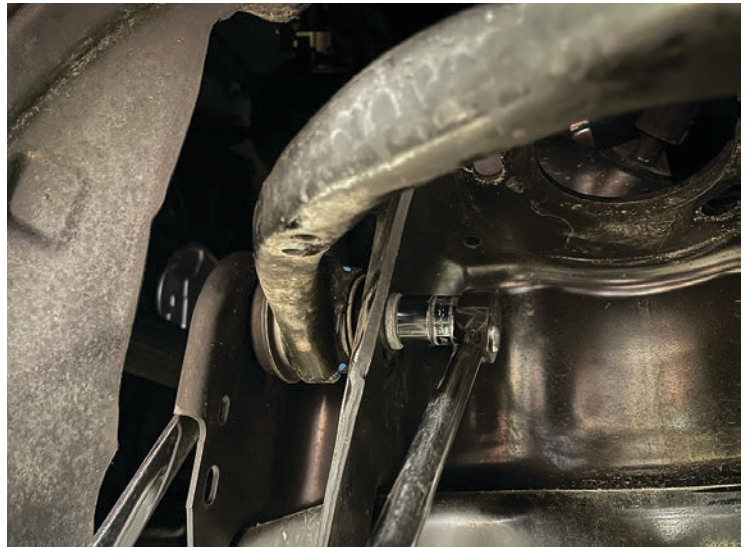

STEP 9

After assembling and greasing the new UCA, clean the upper control arm pocket and apply a light layer of grease where the bushings will contact the frame.

**STEP 10**

Slide the UCA into the frame mounts then install the bolts that secure the UCA to the frame (continued on next page).



STEP 10 CONTINUED

Make sure to install the bolt from the inside of the coil bucket going outward to ensure there is no interference with the coilover.



STEP 11

Now is a good time to pump some grease into the zerks fittings.



STEP 12

Tighten the frame bolts. Torque to factory spec.



STEP 13

Reinstall the coilover.

**STEP 14**

Insert the tapered adapter into the top of the steering knuckle. Use the tapered adapter as a guide for a 9/16" drill bit to drill through the bottom of the ball joint taper. There will only be a minimal amount of material removed to allow the bolt to go through the knuckle.



STEP 15

Keep the tapered adapter in the steering knuckle then swing the UCA down to the steering knuckle. Next make sure the lower misalignment spacer registers onto the tapered adapter. Once seated, install the 9/16" bolt through the UCA and steering knuckle.



STEP 16

Apply a dab of anti-sieze to the 9/16" bolt then torque the nut to 100 ft/lb.

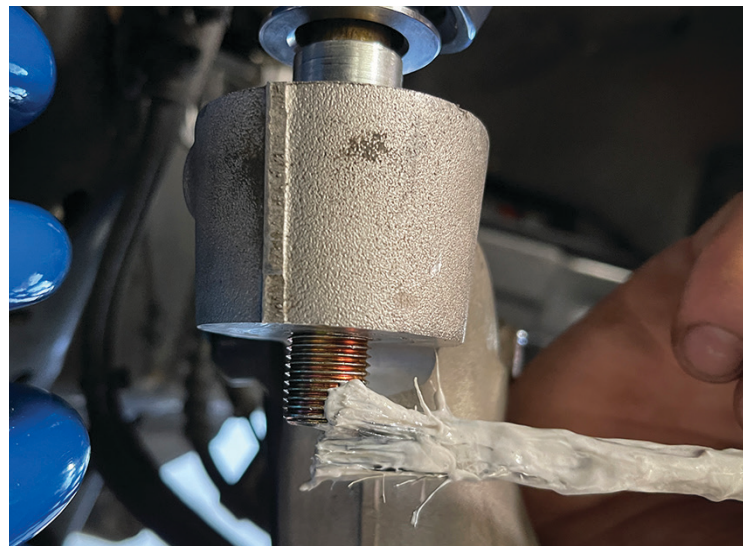

CONGRATS! YOUR UCA'S ARE READY TO GO!

- An alignment will be required after installation is complete.
- Re-torque all hardware after the first 500 miles.
- Re-greasing is required every 3,000-5,000 miles to maximize bushing life and keep noise down.



FOR INSTALL QUESTIONS OR CUSTOMER SERVICE INQUIRIES:

Call 951.737.9682 or email info@chaosfab.com

UPPER CONTROL ARM HARDWARE ASSEMBLY ORDER

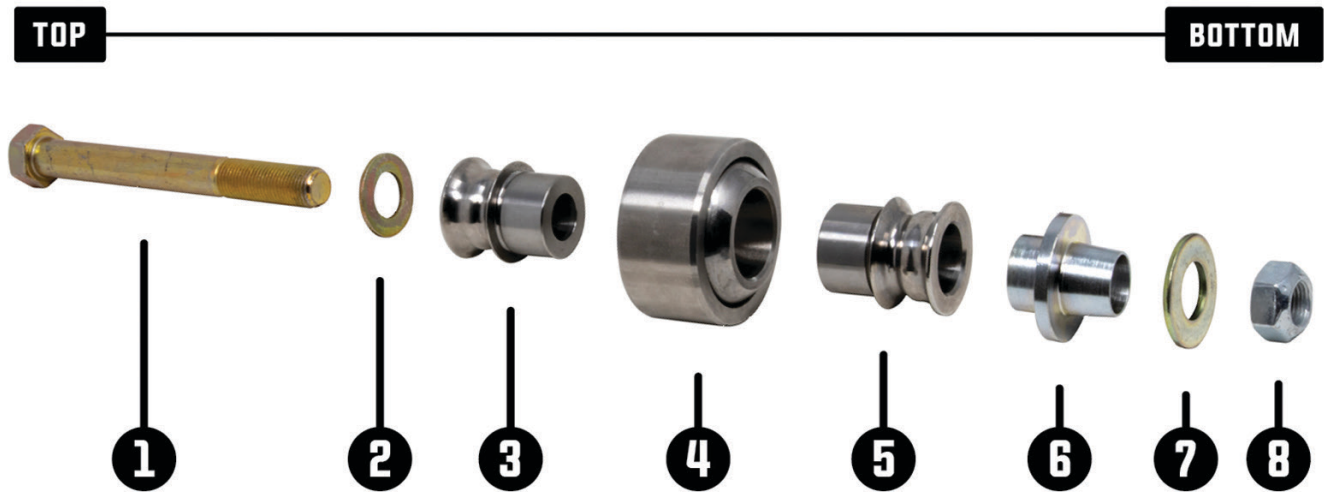

PRIOR TO ASSEMBLY, PLEASE NOTE:

- Items 3, 4 and 5 are pre-installed in the UCA.
- Items 1-6 go above the spindle.
- Item 3 has a 9/16" inner diameter (ID) and item 5 has a 3/4" ID. It is critical the 3/4" ID goes on the bottom so the straight side of the tapered spindle adapter #6 properly registers inside it.
- The tapered spindle adapter #6 goes into the top of the spindle with the tapered side down to ensure proper fitment.
- A spare zerk fitting is supplied with this kit.
- Complete installation instructions available at www.chaosfab.com/install.



HOW TO GREASE TOTAL CHAOS POLYURETHANE BUSHINGS

Polyurethane bushings are prone to squeaking and have the potential of making slight noise even if maintained properly. The reason TOTAL CHAOS uses polyurethane is that it is far stronger and has much less flex than stock rubber bushings. TOTAL CHAOS recommends using Super Lube® Part Number 41150 (or an equivalent PTFE marine grade water proof grease). Avoid using lubricants such as white lithium, any type of penetrant, or spray style lubricant.

STEP 1

Using a mallet, install the dry bushings into the control arm pivots.



STEP 2

With the bushings installed in the control arm, generously apply grease to the inner diameter of the bushings trying to fill the bushing grooves completely with grease.



STEP 3

Generously grease the outer diameter of the supplied TC metal inner sleeves.

**STEP 4**

Using a mallet, arbor press, or smooth jawed vise, install the metal inner sleeve into the bushing.



STEP 5

Using the excess grease, use your finger or a small brush to lubricate the outsides or “hats” of the bushings where they make contact with the plated end washers or control arm pocket.



STEP 6

When installing the zerk fittings, it may be necessary to use a knife or sharp object to clean out the top of the threaded hole so the $\frac{1}{4}$ "-28 NTP threads will catch. When tightening the zerk, DO NOT try and tighten the zerk to the bottom of the thread. It is only necessary to turn the zerk until it gets snug. Then rotate as far as necessary to make the fitting accessible for a grease gun.



ONGOING BUSHING MAINTENANCE

NOTE: The following procedure is applicable to most modern Toyotas and vehicles that utilize our zinc plated end washers on both sides of the pivot bushings. This procedure DOES NOT apply to the following:

- 1998-2007 Land Cruiser 100 Series
- Mitsubishi Montero
- All Ford F150s and Raptors
- All Chevrolet/GMC models
- All Dodge models
- All Nissan models

If you are unsure of the correct procedure to properly grease your bushings, please contact us by calling 951-737-9682 or emailing info@chaosfab.com.

To maximize performance and the lifespan of your polyurethane bushings, some maintenance is required. TOTAL CHAOS recommends greasing your bushings every 5,000 miles (similar to an oil change interval). Greasing more frequently may be required if the vehicle sees dirt and adverse conditions on a regular basis.

STEP 1

To grease TOTAL CHAOS control arms on the vehicle, it is not mandatory to have the vehicle jacked up with the wheel off, although it will make the process much easier.

STEP 2

First you **MUST** loosen the bolt holding the bushings together. This opens an area for the grease to expand when being pumped into the zerk fittings. If you do not loosen the bolt, the grease being pumped into the bushing has nowhere to go. The pressure will cause the bushing to mushroom and be destroyed. If you see the bushing start to deform, immediately stop pumping in grease, grab a small pick, and push in the ball on the zerk fitting to release the excess pressure.



STEP 3

With the bolt loose, pump grease into the zerk fitting until you can see the excess grease bleed out from between the bushing “hat” and the plated end washer (yellow arrow).

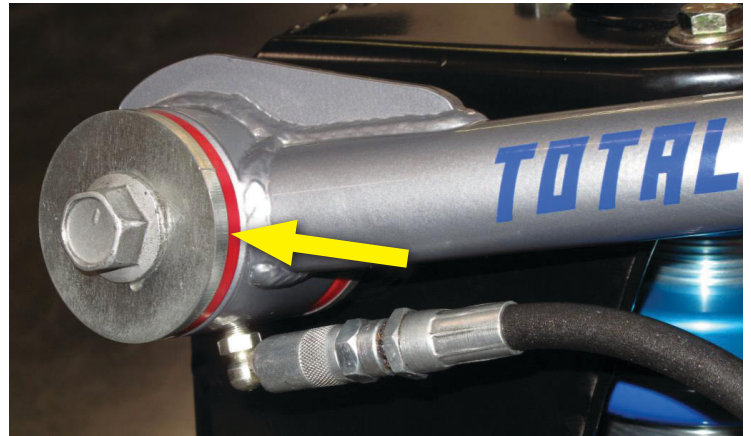

RECOMMENDED ALIGNMENT PROCEDURE

All vehicles equipped with TOTAL CHAOS suspension systems should be taken to an alignment shop that is familiar with off-road suspension systems.

There is increased caster angle built into most TOTAL CHAOS suspension systems. When setting alignment, camber and toe should be set as close to factory spec as possible. Caster will usually be higher than factory specifications. Attempting to bring caster to factory spec will likely result in camber and toe being out of factory specifications, which will result in poor drivability and uneven tire wear. The caster that is built into TOTAL CHAOS suspension systems is sufficient, attempting to add excessive caster into the alignment may result in the inability to adjust camber and toe.

Alignment specifications will vary depending upon:

- Vehicle model
- Suspension kit purchased
- Prior vehicle modifications
- Desired coilover spring pre-load and or ride height

TOTAL CHAOS' suspension products are designed to align with aftermarket shocks that are set to the recommended amount of lift. Some vehicles may not correctly align if the ride height is altered from the recommended settings. If you have followed all of the instructions and the vehicle still won't align correctly, it's likely that there is something installed wrong, or the frame mounting points and/or knuckles may be bent or damaged.

Frequently Asked Questions & Important Things To Read About TC Equipment and Parts

UNIBALLS

TC uses a 100% stainless steel uniball and race for maximum corrosion resistance in all our equipment. The uniballs feature a military grade PTFE Liner that makes much less noise than the standard lined uniballs used in competing brands. This military grade PTFE liner is self-lubricating and does not require any additional lubrication or grease. If you have a ball that is making some noise apply either a layer of Tri-Flow Superior Dry Lubricant (No. TF21013) or CRC Dry PTFE Lube (No. 03044). Uniballs are a consumable item and will need to be replaced when the military grade PTFE Liner wears away. Grabbing your wheel and applying force to see if the ball is moving in the race will determine their maintenance schedule. Each uniball is retained in the uniball cup at the end of the arm with a large snap ring. Wiping the uniballs down with a damp cloth to remove any built up dirt and debris will help extend the life of these parts Replacement parts are available directly from TOTAL CHAOS Fabrication Inc.

POLYURETHANE BUSHINGS

Poly bushings can and will make some noise. They offer many benefits vs. a factory style rubber bushing. To reduce as much noise as possible, TC uses a synthetic grease that contains PTFE called Superlube (No. 41150). If Superlube is not readily available use a good synthetic grease (Mobil 1, Valvoline, etc.). When greasing your pivot bushings on the vehicle it is very important not to force too much grease into the zerk fittings. This will cause excess pressure to become trapped in the pivot and will result in mushrooming the bushing shoulders out of the pivots. To prevent this, first loosen the factory bolt that holds the arms to the frame and separate the washers from the face of the bushings when applicable. This will allow any excess pressure and grease to escape. Don't forget to re-torque the factory bolt when you are finished to a factory torque specification!

ZERK FITTINGS

The grease nipples or zerk fittings that are supplied with our arms are ¼"-28 in size. Should you have a tapped hole that has an excess amount of powder coat in it, use a ¼"-28 tap to clean it up. When installing the zerk fittings take care not to over tighten them as they are hollow and can snap off. When fully installed they will not sit all of the way flush with the pivot, just insert them two or three rotations until they are snug. Don't forget to have them pointing in the right direction so you can get a grease gun onto them once the arms are installed onto the vehicle.

ANTI-SIEZE

To aid in future disassembly of components, we recommend that you liberally apply an anti-seize to all metal on metal contact surfaces such as the ID of the uniball, hi-mis spacers, and inner sleeves. Also, apply it to the threads on any C-lock or Stover nut. This will prevent the C-lock portion of the nut from galling onto the bolt.

BLACK OXIDE COATED PARTS

Some components (such as 4340 axle shafts and lower uniball conversion cups) are coated with Black Oxide. While this will help to prevent rust, depending on your climate you may want to further coat these parts. For axle shafts we wrap a layer of electrical tape the length of the shaft (excluding the splines). For lower uniball conversion cups you can use black spray paint, just be sure to mask of the uniball before painting.

HARDWARE TORQUE

All hardware should be re-torqued after an initial break in period of 50 miles and again at 500 miles. Periodically after that you should inspect your suspension to ensure that nothing is loose, worn, or damaged.

UNIBALL CAPS

We do not use any sort of cap or cover over our uniballs as these actually lead to premature wear and corrosion. With a cap installed moisture and containments work their way up through the underside of the uniball and then become trapped. With no cover this moisture can evaporate and you have easy access to wipe down the uniball periodically.



WARNING

TOTAL CHAOS FABRICATION's aftermarket suspension products and accessories modify a vehicle for uses which exceed conditions anticipated by the vehicle manufacturer. The uses include the high-performance demands required during off-road. These conditions vary in the degree of severity and cannot be controlled by the vehicle or product manufacturer. If the components within the suspension system or accessories become worn due to frequent on-road and/or extreme off-road use, the safety and reliability of the vehicle is at risk. The maintenance of aftermarket equipment to ensure the vehicle occupants safety is entirely your responsibility. Do not purchase TOTAL CHAOS manufactured products or components unless you are willing to accept this responsibility. Do not install any TOTAL CHAOS suspension products or accessories unless you are certified and/or competent at installing the product without causing present or future injury to yourself or other vehicle occupants, other vehicles and their occupants, pedestrians and motorcyclists; seek an authorized installation center.

TOTAL CHAOS FABRICATION long travel suspension systems were designed for off-road use only. This suspension system is not to be modified from its original design in any way. TOTAL CHAOS is not liable nor held responsible for any injury's or death that can occur from off-road use or as the result of product failure. Customer/driver assumes all liability in assuring that the suspension system is properly installed, maintained, and operating in safe conditions. The following are guidelines for maintaining a safe operating vehicle. Safety and reliability are our number one concern.

Visually inspect all equipment for clearance and unusual wear.

Regularly clean and inspect equipment such as suspension components, heim joints, polyurethane bushings and all hardware. Replace items as necessary. All suspension components are available for individual replacement direct from TOTAL CHAOS. We strongly recommend the suspension system be installed by an authorized installation center. TOTAL CHAOS FABRICATION reserves the right to warranty any components that we have determined to be product or material defective. Off-road abuse can damage suspension components.

BREAK IN PERIOD. After every installation we recommend checking the torque of all nuts and bolts to assure that the torque has taken after driving 500 miles. Some minor adjustments may need to be made.

The customer assumes all responsibility for the use of all equipment and the proper maintenance of said equipment. This equipment will alter the center of gravity of your vehicle and also the handling characteristics that you may be accustomed to. Even though your vehicle may have a wider track width it is capable of rolling over. Please wear your seat belt and demand that all passengers do so as well.

Please remember that no matter how well your vehicle is built it is only as safe as you drive it. This equipment is designed to improve the performance of your vehicle. **INCREASING PERFORMANCE ALSO INCREASES YOUR RISK WHILE OPERATING THIS VEHICLE.** The operator must know and understand the vehicles handling characteristics. None of this equipment is guaranteed to be free of defect or to protect the driver or occupants from death or injury in the event of a collision. Please drive in a safe and sane manner.